

TITLE:

CAST BASE HERITAGE COLUMN

DRAWING NUMBER:

SC00122-2

ISSUE:

A

REV. RECORD
Iss X C/NXXXX
Date XX/XX/XX

LANTERN AT 6M
ON 5.5M COLUMN

LANTERN AT 5M
ON 4.5M COLUMN

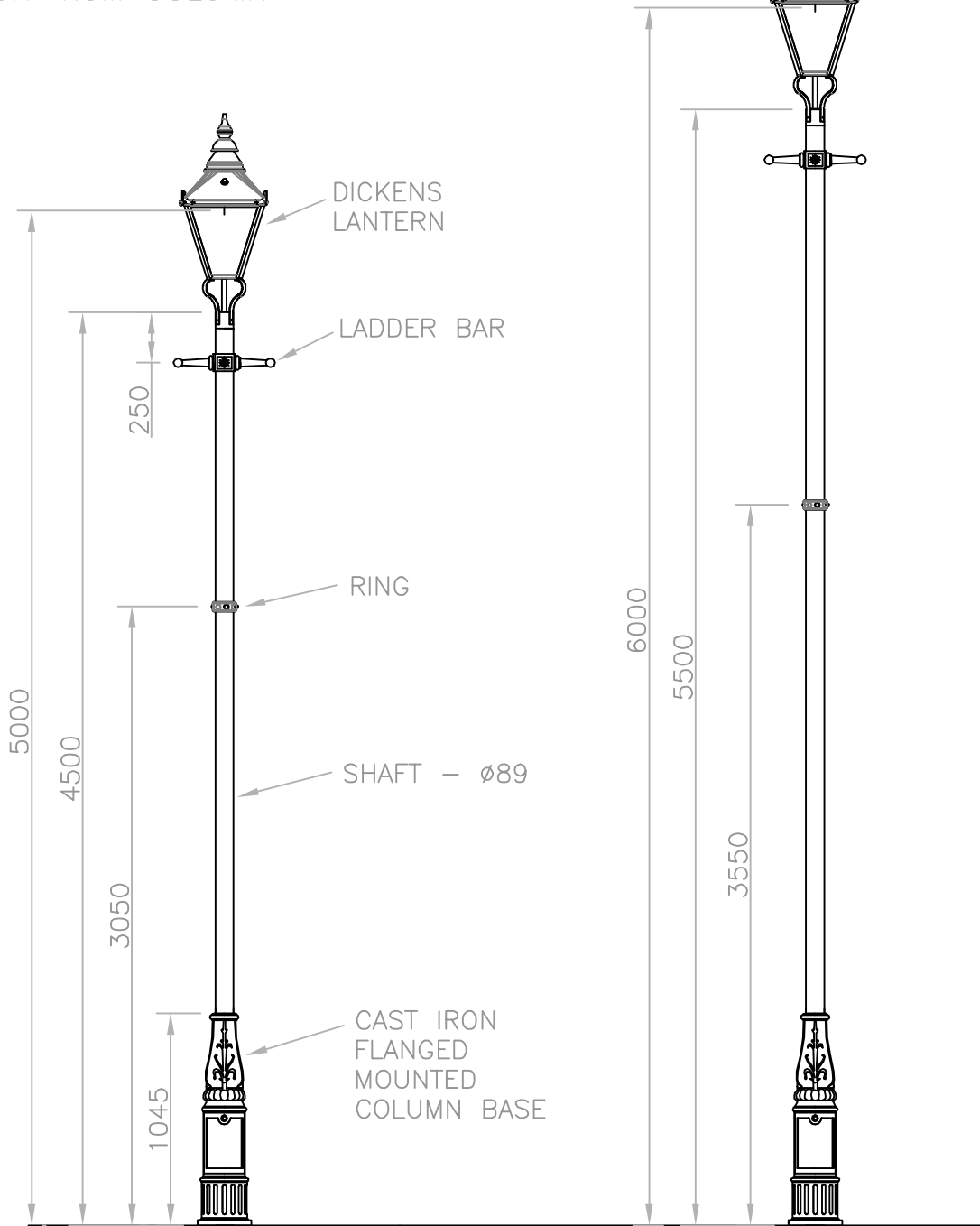

NOTES: (1) ALL DIMENSIONS IN mm. (2) REMOVE ALL BURRS AND SHARP EDGES.

© 2018 PUDSEY DIAMOND ENGINEERING LTD. ALL RIGHTS RESERVED. THIS DOCUMENT OR ANY PART THEREOF MAY NOT BE REPRODUCED, STORED IN A RETRIEVAL SYSTEM OR TRANSMITTED IN ANY WAY WITHOUT WRITTEN PERMISSION FROM PUDSEY DIAMOND ENGINEERING LTD.

LINEAR TOLERANCES UNLESS OTHERWISE STATED: X.00 = ±0.15mm X.0 = ±0.3mm X = ±1mm	ANGULAR TOLERANCES UNLESS OTHERWISE STATED: X = ±1°	MATERIAL: STEEL, C I, ALUMINIUM
		SPEC:

DATE: 03/11/18	SCALE: 1:35	FINISH: PAINT
-------------------	----------------	------------------

DRAWN: IG	CHECKED: AF	3RD ANGLE PROJECTION
--------------	----------------	----------------------

